

SOLAR THERMAL ENERGY, CASE STUDY - REGIONAL INSTITUTE OF PUBLIC HEALTH

Drita Qerimi¹, Gazmend Shala², Arlinda Alimehaj Rrecaj³

¹ UBT, Faculty of Mechatronics Engineering p.n., 10000 Pristine, Kosovo

² Termovent Mechanical Engineer, Miradi e Eperme, 12000 Fushë Kosovë, Kosovo

³ University of Pristina, Faculty of Mechanical Engineering, Traffic and Transport Department, 10000 Pristina, Kosovo

ABSTRACT

In recent years, there has been an increase in the production capacities from RES such as: hydro power plants, wind energy, solar energy, but in Kosovo still the energy produced from lignite continues to dominate as a source primary energy with 77.7%, which, on the one hand enables a security of long-term electricity production, but remains a problem of impact on the environment due to the emission of greenhouse gases and pollutants others. The present chapter discusses mathematical model, simulation program that allows to accurately calculate the yield of a solar thermal system, measurement of active energy and Economic assessment for Regional Institute of Public Health RIPH. Kosovo has an average solar energy potential with the average sun duration for the city of Pristine is 5.44 [h], while the average horizontal irradiation is 3.79 [kWh/m²] per day. In this paper, the first step is analysing and mapping of appropriate surfaces for installation of solar thermal collectors. To realize the demand for sanitary hot water for RIPH, need total gross surface area: 116.64 [m²], with 48 collectors located under corner 33°.

Keywords: renewable energy, solar thermal energy, domestic hot water, saving electricity, CO₂ reduction

1 INTRODUCTION

The solar system that studied is in University Clinical Center of Pristine, Kosovo. The Solar Domestic Water Heating (SDWH) system is providing sanitary hot water for Regional Institute of Public Health, the first part Solar 1 is a Laboratory, a second part Solar 2 serves for the Faculty of medicine, in the following the analyse for Solar 1 is presented Fig.1 shows the roof of the Institute, this roof is more suitable for the installation of solar collectors because doesn't have any obstructions, this part is sufficient space for installation the collectors to meet the demand for sanitary hot water. Based on the daily demand for sanitary hot water the number of collectors that will be placed is calculated. Photovoltaic solar panels, and those for heating water, achieve maximum performance when the sun's rays fall perpendicular to their surface [17]. Figure 1 shows the free surface is 375.15 [m²]. Whereas, according to the calculations the roof surface required for installed solar panels is 116.64 m².



Figure 1 Regional Institute of Public Health.

2 THE DOMESTIC HOT WATER CALCULATION FOR REGIONAL INSTITUTE OF PUBLIC HEALTH

This clinic is located at the University Clinical Center of Pristine, with Latitude 42.64° and Longitude 21.15°. The following should be noted when calculating the hot water demand: Hot Water Demand calculations at other temperatures (T) should be adjusted for the 60°C reference temperature and for the purposes of making this adjustment, the following assumptions and observations should be made:

Contact author: Arlinda Alimehaj Rrecaj

E-mail: arlinda.alimehaj@uni-pr.edu

- The equation assumes that the cold-water temperature (inlet water temperature) is 12 °C and a linear relationship 48 °C is the difference between 60 °C and 12 °C.
- For buildings with seasonal variations in hot water demand such are Hotels, game Lodges and similar premises, the demand may be adjusted by an annual occupancy rate of factor of not less than 70%, [12].
- In calculating demand, is assumed that the daily hot water demand is constant, throughout the year.
- In calculating demand for domestic residential houses, the number of persons is taken to be equal to the number of bedrooms x 1.2, [14].
- In calculating the heat load of the solar water heating system, heat losses in the hot water distribution system are considered.

Since, Solar-only systems cannot guarantee a high enough hot water temperature at the draw-off points as required by EN 806-2 (60°C), and many national regulations within Europe, special attention should be paid to the bacteria Legionella.

In the context of Legionella control the factors that need special consideration for solar hot water systems are: [15].

- The use of storage tanks with frequently changing water temperatures in the range of 10°C to 80°C, so that part of the tank and water is within the temperature range favorable to the growth of Legionella species.
- The use of a storage tank that frequently and for long periods is at a temperature level above 65°C and, as such, disinfects the Legionella and biofilms within the tank.
- The use of non-solar heat sources that may thermally disinfect the hot water.

For an instantaneous solar water heater, a warning should be attached at a clearly visible location on the solar-only system with the following text:

- “When no hot water has been used for more than 2 weeks, the system must be flushed for 5 minutes at a draw-off point other than a shower!”*
- “Flush the system when not used for more than 2 weeks!”*

For all solar-only systems not fulfilling the recommendations before, the solar-only system should be dimensioned such that:

- The temperature of 65°C is reached at the top of the store and 50°C at its bottom, for one hour, once a month, with a probability of 99%, and
- The temperature of 60°C is reached at the top of the store and 45°C at its bottom, for one hour, once a week, with a probability of 90%.

In the pursuit of sustainable development and reduction of environmental impact, energy efficiency has become a paramount concern in the design and operation of buildings and their mechanical systems [18]. To calculate the demand for sanitary hot water for these institutions it is necessary to calculate the monthly average radiation incident on the collector, for this, in this work, the method **Isotropic Sky** was used [2]. Using the isotropic diffuse assumption, the monthly average radiation incident on the collector can be estimated. A collector is to be installed in Pristine, Regional Institute of Public Health, with latitude $L = 42^{\circ}64'N$ at a slope of 33° to the south. The monthly mean solar radiation on an unshaded tilted surface can be expressed as:

$$\overline{H}_T = \overline{H} \left(1 - \frac{\overline{H}_d}{\overline{H}} \right) \cdot \overline{R}_b + \frac{\overline{H}_d}{\overline{H}} \cdot \left(\frac{1 + \cos \beta}{2} \right) \cdot \overline{H} + \overline{H} \cdot \rho_g \left(\frac{1 - \cos \beta}{2} \right) \quad (1)$$

\overline{H} - Monthly average total insolation on a terrestrial horizontal surface (MJ/m²-d), Table 1. -The ground reflectance is 0.2 for all months except December and March ($\rho_g = 0.4$) and January and February ($\rho_g = 0.7$) [2].

\overline{H}_0 - monthly average daily total insolation on an extraterrestrial horizontal surface, calculated with interpolation from [2] for each month as a function of latitude, together with the recommended dates of each month.

Table I - Horizontal Irradiation [kW·h/m²]

Month	Daily	Monthly
Jan	1.64	50.90
Feb	2.44	68.44
Mar	3.41	105.68
Apr	4.31	129.37
May	5.24	162.60
Jun	6.18	185.65
Jul	6.44	199.69
Aug	5.70	176.83
Sep	4.15	124.51
Oct	2.80	87.03
Nov	1.75	52.68
Dec	1.38	42.90
Annual	3.79	1386.32

The monthly average clearness index, \overline{K}_T , is defined as:

$$\overline{K}_T = \frac{\overline{H}}{\overline{H}_0} \quad (2)$$

The amount of insolation on a terrestrial surface at a given location and time depends on the orientation and slope of the surface. In the case of flat-plate collectors installed at a certain fixed angle, system designers need to have data about the solar radiation on the surface of the collector.

For $h_{ss} \leq 81.4^{\circ}$ and $0.3 \leq \overline{K}_T \leq 0.8$

$$\frac{\overline{H}_d}{\overline{H}} = 1.391 - 3.560\overline{K}_T + 4.189\overline{K}_T^2 - 2.137\overline{K}_T^3 \quad (3)$$

and for $h_{ss} > 81.4^{\circ}$ and $0.3 \leq \overline{K}_T \leq 0.8$

$$\frac{\overline{H}_d}{\overline{H}} = 1.311 - 3.022\overline{K}_T + 3.427\overline{K}_T^2 - 1.821\overline{K}_T^3 \quad (4)$$

With the monthly average daily total radiation \overline{H} and the monthly average daily diffuse radiation \overline{H}_D known, the monthly average beam radiation on a horizontal surface can be calculated by:

$$\overline{H}_B = \overline{H} - \overline{H}_D \quad (5)$$

The ratio of the average daily beam radiation on the tilted surface to that on a horizontal surface for the month is \overline{R}_b

$$\overline{R}_b = \frac{\cos(L - \beta) \cdot \cos(\delta) \cdot \sin(h'_{ss}) + \left(\frac{\pi}{180}\right) \cdot (h'_{ss}) \cdot \sin(L - \beta) \cdot \sin(\delta)}{\cos(L) \cdot \cos(\delta) \cdot \sin(h_{ss}) + \left(\frac{\pi}{180}\right) h_{ss} \cdot \sin(L) \cdot \sin(\delta)} \quad (6)$$

Where:

L Local longitude,

δ Declination,

h_{ss} Hour angle at sunset [2],

h_{ss}' Hour angle for the tilted surface for the mean day of the month, which is given by:

$$h_{ss}' = \min \left[\begin{array}{l} \cos^{-1}(-\tan L \cdot \tan \delta) \\ \cos^{-1}(-\tan(L - \beta)\tan \delta) \end{array} \right] \quad (7)$$

where “min” means the smaller of the two items in the brackets. The results for Average daily total radiation for 12 months on the tilted surface for Regional Institute of Public Health presented in Table 2. Energy quantities are in mega joules per square meter. It is difficult to put limits of accuracy on them, they are probably no better than $\pm 10\%$.

In this clinic was installed a solar thermal system, financed by the World Bank, with a total of 48 collectors divided into two parts, this system serves for laboratory part (Solare 1) and the Faculty of Medicine (Solare 2), where: Solare 1
 $G = 4000$ [l] – the volume of the boiler,
 $T_{\min} = 12$ [°C] – the temperature in boiler entry (water supply),
 $T_{\max} = 50$ [°C] – the temperature at the exit of the boiler,
 $C_p = 1.16$ [Wh/kgK] - specific capacity of water [15],
 $h = 0.81$ – utilization coefficient [6],
 $p = 2.23$ [m²] – effective area of the collector,
 $q = 4.746$ [kWh/m²day] – the capacity of sunlight [1].

$$Q = \frac{G \cdot C_p (T_{\max} - T_{\min})}{1000} = 176.32 \text{ [kWh/day]} \quad (8)$$

Collector area:

$$S = \frac{Q}{q \cdot h} = 45.87 \text{ [m}^2\text{]} \quad (9)$$

The number of collector is 21

$$n = \frac{S}{p} = 21 \text{ [colector]} \quad (10)$$

3 CALCULATION WITH SOFTWARE T*SOL 2018

T*SOL is the simulation program that allows to accurately calculate the yield of a solar thermal system dynamically over the annual cycle, [5]. For evaluation or design of solar systems (with components collector, collector loop, heat exchanger and tanks), many parameters must be studied and experimented.

However, this is not always possible due to different weather types and the difficulty of data gathering and certainty.

That's why simulation presents various interesting options for design and simulation of physical behavior, there will be always errors and uncertainties, because solar energy systems are transient in nature. Therefore, simulation and experimentation are complementary. However, modelling assumptions should be valid to avoid big uncertainties. To design or optimize a solar system with T*SOL, the following steps must be followed:

a) Calculation of Energy Balance

A thermal energy balance is generated to calculate status and temperature changes during a simulation period. Mathematically, this means the numerical solution of a differential equation [5].

Temperature difference = Total of all input and output energies/Total of all heat capacities.

Energy input can be (depending on the component):

- Irradiation,
- Heat supply to the heat exchanger,
- Heat transfer by mass flow due to consumption or circulation,
- Intermixture of storage tank layers.

Energy output can be:

- Heat losses by radiation from the collector (quadratic transmission coefficient),
- Heat losses at the insulation of the collector, the piping (collector loop or circulation), the valves, or the storage tanks,
- Heat transfer to the heat exchanger,
- Heat transfer by mass flow due to consumption or circulation,
- Intermixture of storage tank layers.

The heat capacities of the following components are considered:

- Collector
- Piping of the collector loop
- Storage tank content

Table II- Results for RIPH with $L = 42^{\circ}64'$ N

Parameters Object		\bar{H} [MJ/m ²]	\bar{H}_0 [MJ/m ²]	\bar{K}_r	\bar{H}_d / \bar{H}	\bar{R}_b	h_{ss} [°]	h_{ss}' [°]	\bar{H}_T [MJ/m ²]
Regional Institute of Public Health	Jan	5.911	13.663	0.433	0.462	2.254	69.394	86.278	10.014
	Feb	8.798	18.769	0.469	0.423	1.796	77.771	87.761	13.038
	Mar	12.27	26.186	0.469	0.46	1.409	87.772	89.589	14.923
	Apr	15.52	33.861	0.458	0.47	1.119	98.783	91.614	16.156
	May	18.88	39.436	0.479	0.45	0.95	108.26	93.313	17.977
	Jun	22.28	41.7	0.534	0.397	0.883	113.11	94.152	20.352
	Jul	23.19	40.494	0.573	0.362	0.912	110.908	93.774	21.583
	Aug	20.53	35.819	0.573	0.362	1.041	102.727	92.329	20.801
	Sep	14.94	28.744	0.52	0.41	1.281	92.043	90.377	17.166
	Oct	10.11	20.922	0.483	0.408	1.654	81.04	88.354	13.856
	Nov	6.322	14.763	0.428	0.467	2.117	71.61	86.664	9.951
	Dec	4.982	12.116	0.411	0.487	2.422	66.933	85.855	8.583

b) Calculation of Irradiation

In the supplied climate files, irradiation to the horizontal plane is given in watts per square meter of active solar surface. The program converts this to the tilted surface during the simulation and multiplies it by the total active solar surface. This model considers the anisotropy factor for circumsolar radiation and the ground reflection factor (= 0.2). Irradiation on the collector area (active solar surface) is calculated from the radiation strength (W/m²) on the horizontal plane: the height of the sun and the solar azimuth is determined on the basis of the date, time, and latitude.

c) Calculating Collector Thermal Losses

The energy absorbed by the collector and output to the collector loop less heating losses is calculated as follows:

$$P = G_{dir} \cdot \eta_o \cdot f_{IAM} + f_{IAMdiff} \cdot G_{diff} \cdot \eta_o - k_o \cdot (T_{cm} - T_A) - k_q \cdot (T_{cm} - T_A)^2 \quad (11)$$

with :

- G_{dir} Part of solar irradiation striking surface
- G_{diff} Diffuse solar irradiation striking a tilted surface
- T_{cm} Average temperature in the collector
- T_A Air temperature
- f_{IAM} Incident angle modifier.
- k_o Heat transfer coefficient (in W/m²/K)
- k_q Heat transfer coefficient (in W/m²/K²).

d) Calculation of Primary Energy Consumption

Consumption values, efficiencies, solar fractions, and other parameters can be calculated from the temperatures and the energy flows of the system. In this case, district heating is calculated from the energy transferred to the auxiliary heating at the heat exchanger via the heat equivalent and the efficiency of the auxiliary heating.

e) Calculation of CO₂ Emissions

The CO₂ emissions saved by the solar system are calculated in the results summary. For this, it is necessary to know which type of primary energy is saved by the solar system.

f) Calculating Efficiency and the Solar Fraction

The collector loop efficiency is defined as follows:

$$\text{Collector Loop Efficiency} = \frac{\text{Energy output from the collector loop via the heat exchanger}}{\text{Energy irradiated onto the collector area (active solar surface)}}$$

The system efficiency is defined as follows:

$$\text{System efficiency} = \frac{\text{Energy output from the solar system}}{\text{Energy irradiation on to the collector area (active solar surface)}}$$

The solar fraction is defined as follows:

$$\text{Solar fraction} = \frac{\text{Energy supplied to the standby tank from the solar system}}{\text{Total energy supplied to the standby tank (Solar system + auxiliary heating)}}$$

3.1 MODELING AND SIMULATION OF SOLAR WATER HEATING SYSTEMS

Based on the calculations we have 21 collectors but in the clinic there are installed $2 \cdot 24 = 48$ collectors, with a total of 6 modules with 8 collectors.

3.1.1 Simulation

Based on the calculations made for the volume of the boiler and number of collectors, the following system is obtained.

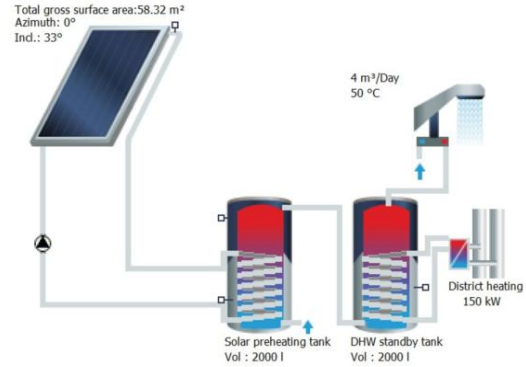

Figure 2 The DHW system for Regional Institute of Public.

In the following are presented the simulations with this software for some institutions. Tab. 3 shows the basis data for this station. As a general conclusion it can be suggested that for sanitary hot water temperature for 50°C: the total solar fraction for Regional Institute of Public is 60%, the solar contribution is 40819 kWh, the CO₂ emissions is 9925 kg, and the Savings District heating is 45947 kWh.

4 THE F-CHART METHOD

This and the following sections outline the f-chart method for estimating the annual thermal performance of active heating systems for buildings (using either liquid or air as the working fluid) where the minimum temperature of energy delivery is near 20°C. The f-chart method provides a means for estimating the fraction of a total heating load that will be supplied by solar energy for a given solar heating system. The primary design variable is collector area; secondary variables are collector type, storage capacity, fluid flow rates, and load and collector heat exchanger sizes.

The two dimensionless groups are:[2]

$$X = F_R \cdot U_L \cdot \frac{F'_R}{F_R} \cdot (T_{ref} - T_a) \cdot \Delta t \cdot \frac{A_c}{L} \quad (12)$$

$$Y = F_R \cdot (\tau\alpha)_n \cdot \frac{F'_R}{F_R} \cdot \frac{(\tau\alpha)}{(\tau\alpha)_n} \cdot \overline{H_T} \cdot N \cdot \frac{A_c}{L} \quad (13)$$

where:

- A_c Collector area (m²)
 - F'_R Collector heat exchanger efficiency factor [%]
 - F_R Collector heat removal factor [%]
 - U_L Collector overall loss coefficient (W/m²/°C)
 - Δt Total number of seconds in month
 - \overline{T}_a Monthly average ambient temperature (°C) [10]
 - T_{ref} Empirically derived reference temperature (100°C)
 - L Monthly total heating load for space heating and hot water (J)
 - $\overline{H_T}$ Monthly average daily radiation incident on collector surface per unit area (J/m²)
 - N Days in month
 - $\tau\alpha$ Monthly average transmittance – absorptance product.
- Table IV shows the results of these calculations.

Table III- The results of studied parameters

Parameters Object		Solar contribution to DHW [kWh]	DHW solar fraction [%]	CO2 emissions avoided [kg]	E-SL to tank [kWh]	Energy from Auxiliary heating [kWh]	Savings District heating [kWh]
Regional Institute of Public Health – Solar I	Months	50°C	50°C	50°C	50°C	50°C	50°C
	Jan	2042	32	474	2043	4336	2196
	Feb	2357	37	547	2329	4067	2534
	Mar	3408	52	792	3413	3142	3665
	Apr	3792	64	887	3861	2133	4109
	May	4202	74	1038	4254	1500	4806
	Jun	4339	82	1096	4470	965	5075
	Jul	4664	93	1185	4794	349	5487
	Aug	4517	92	1148	4608	369	5314
	Sep	3854	76	953	3941	1241	4413
	Oct	3621	61	865	3606	2272	4006
	Nov	2447	39	572	2432	3861	2647
	Dec	1577	32	366	1562	3426	1696
Year	40819	60	9925	41315	27660	45947	

Table IV- Monthly and Annual Performance

Mon	T [°C]	H _T [MJ/m ²]	L [GJ]	X _c	Y	f	fL [GJ]
Jan	0.2	10.014	22.47	4.775	0.627	0.285	6.356
Feb	2.5	13.038	20.30	4.548	0.816	0.43	8.725
Mar	6.6	14.923	22.47	4.145	0.934	0.526	11.83
Apr	11.1	16.156	21.75	3.702	1.011	0.596	12.97
May	15.64	17.977	22.47	3.255	1.125	0.686	15.41
Jun	19.72	20.352	21.75	2.854	1.274	0.787	17.11
Jul	22.21	21.583	22.47	2.609	1.351	0.839	18.85
Aug	22.15	20.801	22.47	2.615	1.302	0.814	18.30
Sep	16.32	17.166	21.75	3.189	1.075	0.661	14.36
Oct	11.54	13.856	22.47	3.659	0.867	0.508	11.43
Nov	6.26	9.951	21.75	4.178	0.623	0.311	67.62
Dec	1.2	8.583	22.47	4.676	0.537	0.221	49.64
Year		184.401	264.6				147.1

The fraction of the annual heating load supplied by solar energy is determined by repeating the calculation of X, Y and f for each month and summing the results as indicated by:

$$F = \frac{\sum f_i \cdot L_i}{\sum L_i} \quad (14)$$

When this process is repeated for all 12 months the annual solar contribution is estimated to be 55.6%

5 THE MAIN SYSTEM COMPONENTS

The system was designed to generate hot water for DHW use. The main components of the solar hot water heating system at the Regional Institute of Public Health (Fig. 3) are:

Closed-Loop System – The system is designed as a standard closed loop system, where a pump circulates a water/propylene glycol mixture through the collectors and an external heat exchanger.

Infectious Diseases Clinic – A total of six modules were installed at the Clinic, with two parts: **Solar I** of three modules plumbed in series, three set of eight panels are plumbed in parallel, same in **Solar II** of three modules plumbed in series, three set of eight panels are plumbed in parallel. **Preheat Tank** – There are two preheat tanks in this system (with 2*2000 liters), that heated water from the solar thermal collectors and preheat the domestic hot water before it is supplied to the auxiliary tanks. As shown in Figure 3, the preheat tanks are heated solely by the collector array. **Auxiliary Tank** – **Regional Institute of Public Health** system uses a standard Auxiliary Tank with 2000 liter (Type KODSAN KCD, the diameter 1260 [mm] and the height 2230 [mm] [3]). Pre-heated water from the preheat tanks is fed to the auxiliary tank where it is heated to the hot water delivery set point, if necessary, and supplied to the facility. In the winter season this tank heated from District Heating.

External Heat Exchanger – An external heat exchanger transfers heat from the solar collectors to the pre-heat tanks.

Solar Pump Station – Circulation pumps circulate water through the solar thermal loop and the external heat exchanger. A separate set of pumps circulate fluid from the pre-heat tanks to external heat exchangers.

Solar Controller – Under normal operations at the Bean Center, the circulating pumps serving the solar collectors and the solar storage tanks are started when the collector temperature exceeds the solar tank storage and stopped when the collector temperature is less than the solar storage tank.

Installed Costs – The installed system cost of the 48-panel system at the Regional Institute of Public Health is **42816 [€]** (for both Solar I and Solar II). A photo of the 48-panel installation at the Regional Institute of Public Health is provided in Figure 3. The presence of dirt or dust causes losses of solar panels efficiency up to 40% [16].



Figure 3 Regional Institute of Public System Installation (collectors, Preheat Tank, Auxiliary Tank, Controller).

5.1 STUDIED SYSTEM SCHEME IN AUTOCAD

With the application of software AutoCAD all components of Solar Hot Water System (Solar 1 and Solar 2) at the Regional Institute of Public Health are drawn in Figure 3. It should be mentioned that the entire system uses renewable energy, only pump and controller is electrical equipment. In this station the measurements are registered 24 hours every 5 minutes beginning May to September.

It is worth mentioning that in this station there is mainly energy exchange during the 24 hours, and very rare the expression N/A. The maximum value in this station is 1100 [Wh], on 31 July, which is shown in Fig. 6.

In the Regional Institute of Public Health, there is an exchange of energy almost 24 hours, for this reason the solar contribution value is higher.

In the following, an annual overview of the Regional Institute of Public Health was made.

Annual solar contribution, money saves and CO₂ reduction was calculated as follows:

- Annual solar contribution data
- Money saves depend on the fuel, in this case electricity:
- CO₂ reduction
- Annual solar contribution Tab. 1 [kWh]
- Boiler efficiency 0.95
- Unit price of electricity 0.079 [€/kWh]
- CO₂ emission per kWh electric 0.219 [kgCO₂/kWh]

$$E_x = 2191 \text{ kWh} \cdot \frac{1}{0.95} \cdot 0.0779 \text{ euro/kWh} = 179.662 \text{ euro}$$

Table V shows the amount saved by using solar energy for water heating is 3347.158 [€], but the maintenance of the system was not included in this value. The system reduced CO₂ emission by 9409.854 [kg], which is an important amount of reduced CO₂ in the atmosphere.

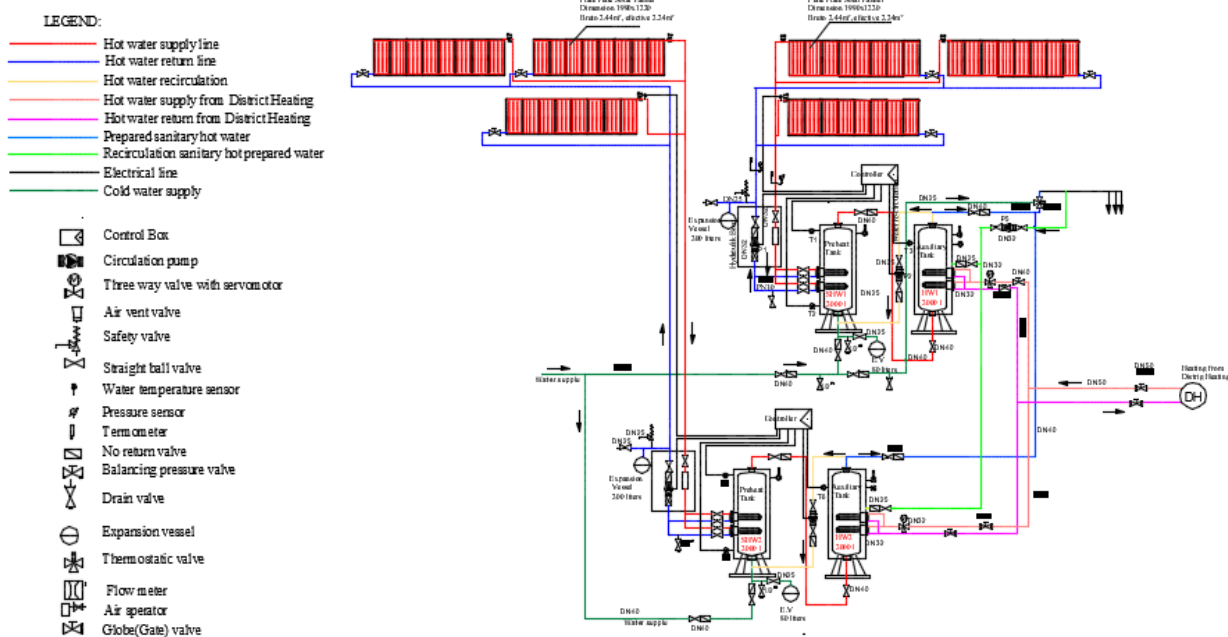

Figure 4 Schematic Solar Hot Water System at the Regional Institute of Public Health.

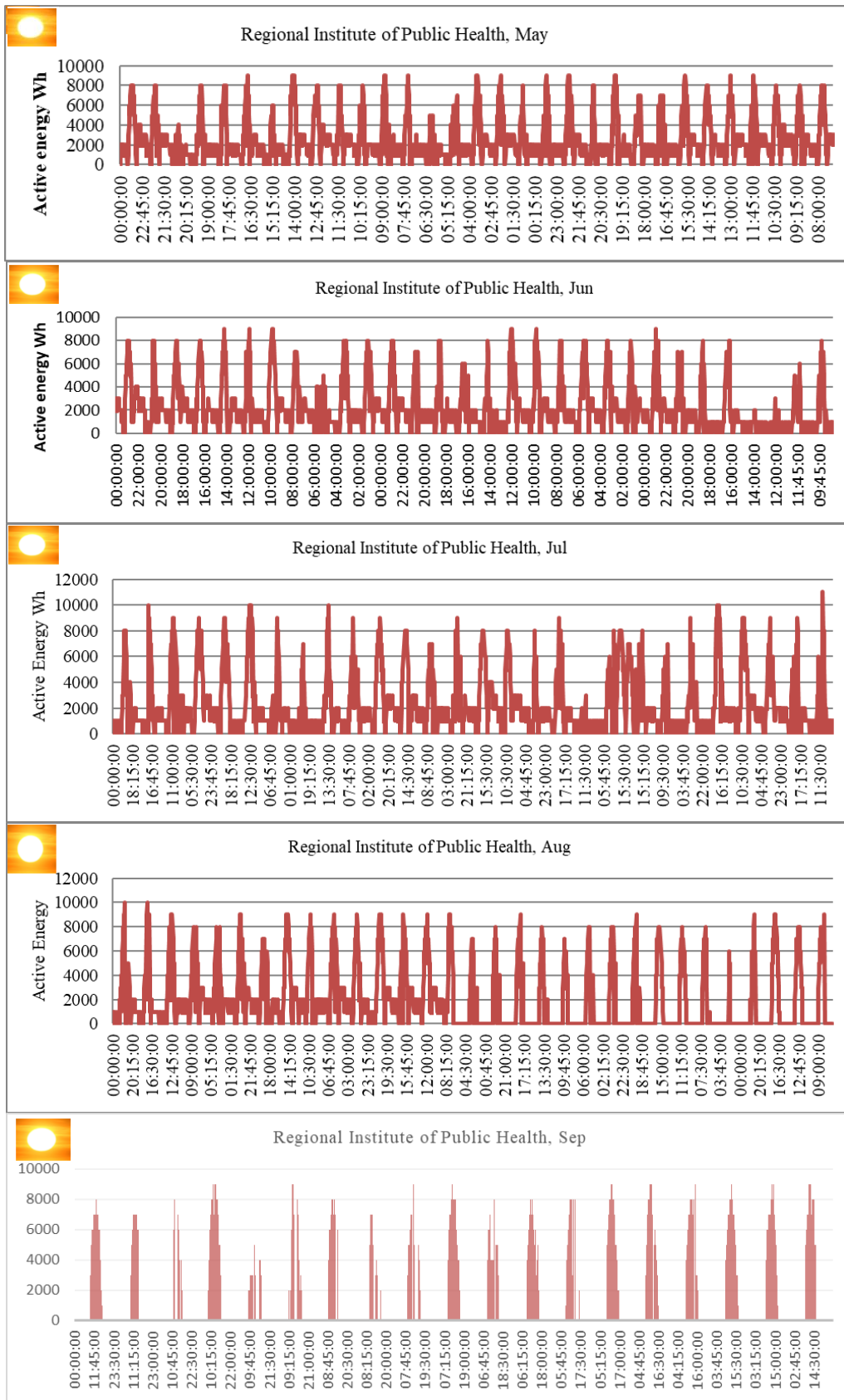

Figure 5 Solar Hot Water System – Active Energy measured from May to September.

Table V- Monitored Regional Institute of Public Health

Months	Solar contribution [kWh]	Annual money saves [€]	Annual CO ₂ reduction [kg]
Jan	2042	167.44	470.73
Feb	2357	193.274	543.35
Mar	3408	279.456	785.63
Apr	3792	310.944	874.15
May	4202	344.564	968.67
Jun	4339	355.798	1000.25
Jul	4664	382.448	1075.17
Aug	4517	370.394	1041.28
Sep	3854	316.028	888.44
Oct	3621	296.922	834.73
Nov	2447	200.654	564.09
Dec	1577	129.314	363.54
Annual	40819	3347.158	9409.854

6 ECONOMIC ASSESSMENTS FOR RIPH

In the investigation of the economic benefits of utilizing solar energy instead of conventional sources of energy, it is mandatory to take into consideration all the economic parameters of such an investment. It is assumed that the cost of the solar water heater is paid at the beginning and the value for RIPH for this clinic is 21408 [€]. The life span of the solar water heater is taken to be 20 years (starting from 2018 to 2038), the thermal performance degradation of the system is assumed to be 1% per year [11], unit price of electricity in Kosovo is 0.0779 €/kWh. Based on results obtained in Table III for cumulative cash flow analysis.

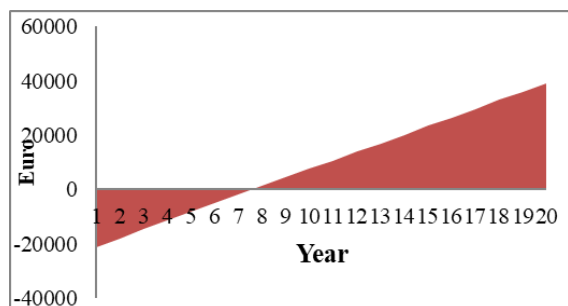

Figure 5 The result of cumulative cash flow analysis for the city of Regional Institute of Public Health

For this clinic, the annual energy needs covered by a solar water heater are founded 65% of the annual water heating use. Moreover, the cumulative cash flow analysis result is shown in Fig. 5. The simple and equity payback periods are 7.6 years.

7 CONCLUSIONS

This paper investigates solar thermal energy for one system that install in one social institution in Pristina, which increases the quality of life, thus serves with hot sanitary water. Improving the performance and utilization of solar thermal systems will increase solar energy harvesting and reduce the dependency on fossil-based energy sources.

This review article focuses on:

- Environmental characteristics for Pristina:
 - Global horizontal radiation 1351 [kWh/m²]
 - Insolation 5.44 [h]
 - Air temperature 11.3 [°C]
- RIPH located at 42.64°0" N and 21.15°0" E.
- Appropriate roof space to put the collectors 375.15 [m²].
- The number of collectors is 24.
- The result of simulation with TSOL software:
 - Solar fraction for Pristine is 60%
 - Solar contribution is 40819 [kWh]
 - CO₂ emissions avoided are 9925 [kg]
 - Savings District heating is 45947 [kWh].
- The f-chart method is used step by step based on the Duffie and Beckman to calculate Monthly and Annual Performance for RIPH:
 - Estimated annual solar contribution 40861.1 [kWh]
 - The fraction of the annual heating load supplied by solar energy is 55.6%.
- Active energy - In this station the measurements are registered 24 hours every 5 minutes beginning May to September. It is worth mentioning that in this station there is mainly energy exchange during the 24 hours, and very rare the expression N/A.
- Monitored Regional Institute of Public Health:
 - the amount saved by using solar energy for water heating is 3347.158 [€]
 - the system reduced CO₂, emission avoided is 9409.854 [kg]

Significantly increasing the use of renewable energy is an urgent task for the time being. The use of solar thermal energy in Kosovo is being used mainly in social institutions, which aims to increase the quality of life and conserve energy. The return of the investment is made after 7.6 years, but the protection of the environment is important when it is known that Kosovo has a high level of pollution, especially in the winter season.

CONFLICTS OF INTEREST

The authors declare no conflict of interest.

REFERENCES

- [1] D. Qerimi, C. Dimitrieska, S. Vasilevska, A. Alimehaj. *Modeling of the Solar Thermal Energy Use in Urban Areas*, 2020.
- [2] J. Duffie, W. Beckman, *Solar Engineering of Thermal Processes*, Fourth Edition.
- [3] Kodsan - Product catalogue ,2017.
- [4] Renewable 2023 Global Status Report - REN21.
- [5] T*SOL® Pro Version 5.5 Design and Simulation of thermal solar systems.
- [6] Test Report, Thermal Performance of a Solar Collector 2012.
- [7] *Urban development plan "Pristina 2012-2022"*, September 2013.

- [8] Dinçer and C. Zamfirescu, *Sustainable Energy Systems and Applications*, LLC 2011.
- [9] Energy regulatory office, annual report 2023. Prishtina March 2024.
- [10] Instituti hidrometeorologjik i Kosoves.
- [11] *Solar Heat Worldwide*, Edition 2024.
- [12] J. Twidell and T. Weir. Renewable Energy Resources. A. Ramos, I. Guarracino, A. Mellor, D. Alvarez, P. Childs, J. Nicholas, E. Daukes, N. Markides. *Solar-Thermal and Hybrid Photovoltaic-Thermal Systems for Renewable Heating*: May, 2017.
- [13] N.Sahiti, M. Pireci, B. Verselaj, *Burimet e ripërtitshme te energjisë*.
- [14] Code of practice – The CEN/TR 16355 technical report of CEN/TC 164/WG 2 on Legionella applied to solar hot water systems.
- [15] P. Iodice, A. Amoresano, G. Langella, Thermodynamic analysis of screw expanders at part-load working conditions: energy losses, fluid leakage and overall efficiency, *International Journal of Mechanics and Control*, Vol. 24, No. 1, pp. 89-96, 2023.
- [16] M. Cristodaro, S. Fortuna, A. Greco, A. C. Petrolino, G. Carbone, Design of solar panels cleaning device - Cleanator, *International Journal of Mechanics and Control*, Vol. 23, No. 01, pp. 35-44, 2022.
- [17] S. Poçari, L. Lamani, M. Alcani, A. Hoxha, Implementation of PID position control for a photovoltaic system using mathematical model and LabVIEW, *International Journal of Mechanics and Control*, Vol. 25, No. 01, pp. 9-14, 2024.
- [18] G. Mustafaraj, K. Dhoska, A. Sulejmani, O. Koça, E. Spaho, Applied energy efficiency measures in industrial building by using EnergyPlus software, *International Journal of Mechanics and Control*, Vol. 25, No. 01, pp. 37-44, 2024.

